

VOMP 600



Vertical Oil Mist Precipitator



TRION[®]
air purification systems

VOMP 600



DESCRIPTION

Trion's Vertical Oil Mist Precipitator (VOMP) 600 electronic mist collector is designed to remove oil/coolant mist and smoke at the source. The VOMP 600 brings you in compliance with OSHA and EPA standards, improves employee safety and working conditions, protects equipment, plant fixtures and work in progress, and reduces plant maintenance costs. The VOMP 600 can be mounted directly on the machine tool for source capture of contaminants such as water-soluble, synthetic and petroleum-based coolants and smoke.

APPLICATIONS

The VOMP is ideal for:

- Screw machines
- Surface and centerless grinders
- CNC machining centers
- Turning lathes
- Parts cleaning systems
- Various other applications

FEATURES & BENEFITS

- High efficiency – up to 95% efficient on 0.3 micron particles.
- Cleans and re-circulates indoor air – no expense to reheat or cool air.
- Wall, platform or machine mounting – eliminates the need for elaborate duct work and saves floor space.
- Can be wired directly to the machine tool control – operates only when the machine tool does.
- Spiked ionizer increases efficiency and reliability.
- Collector cell is made of all-aluminum plates, which eliminates filter replacement costs.
- Low airflow resistance reduces energy costs.
- Venturi-assisted high-voltage insulator forces clean air across critical areas of the insulator to provide longer service intervals.

How It Works

Trion's VOMP 600 utilizes the principle of electrostatic precipitation. Air is drawn by the motor/blower through an impinger pre-filter which traps large particles. Remaining particles, some as small as 0.01 microns, pass into a strong electrical field (ionizing section) where the particulate receives an electrical charge. The charged particles then pass into a collector plate section made up of a series of equally spaced parallel plates. Each alternate plate is charged with the same polarity as the particles, which repel, while the interleaving plates, which are grounded, attract and collect oil/coolant mist, and smoke. The air is then returned fresh and clean.

HIGH VOLTAGE INSULATOR

The high voltage components in the ionizing/collector cells are supported with insulators of a completely new design. A strategically located air passage and venturi spacer direct clean air at increased velocity across critical areas of the insulator. These areas, under positive pressure, force contaminated air away from the insulator (see Figure 1) creating the following benefits:

- Insulators stay clean, improving overall collecting efficiency.
- Higher percentage of water in soluble oil can be collected.
- Reduced maintenance.

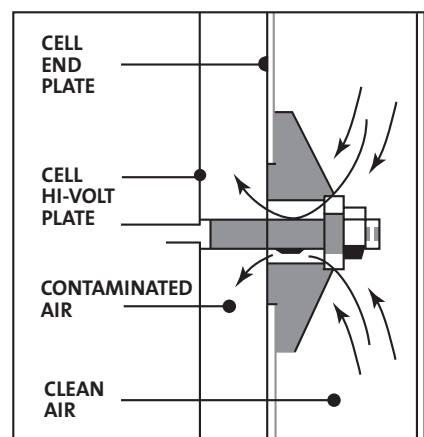
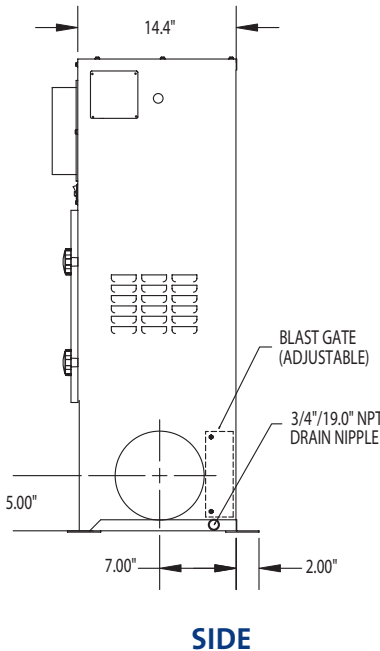
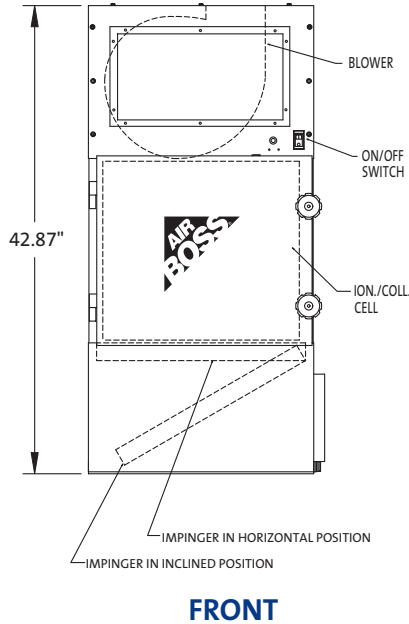
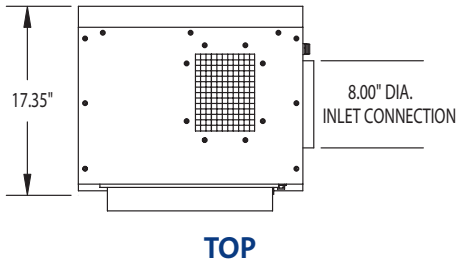
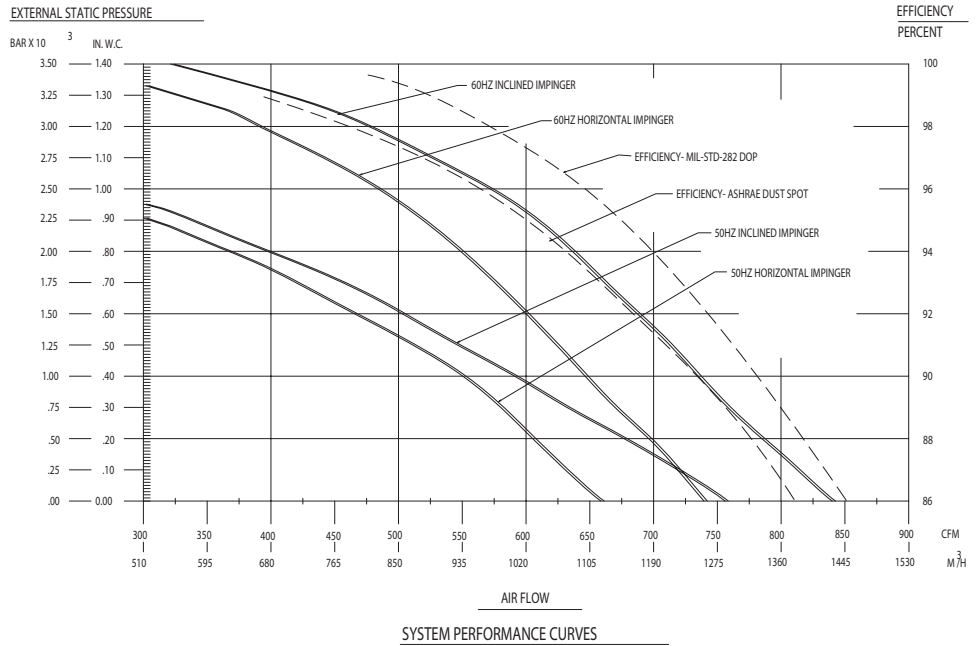

Figure 1

Specifications



TECHNICAL DETAILS	VOMP 600
Air Volume CFM	300-800
Input Voltage	120-240V / 60Hz / 1ph
Output Voltage (KVDC)	11/5.5
Fan	1/2 HP
Max Static IN. W.C.	2.3" EXT. S.P.
No. of Cells	1 Each
Cell Weight (lbs.)	29 lbs.
UNIT DIMENSIONS	
Height (in)	42.9"
Length (in)	17.4"
Width (in)	21.7"
Weight (lbs)	121 lbs.
Drain Dia. (in)	3/4" NPT
Inlet Connection	8" Dia. - Right Side
Prefilter	Impinger or Metal Mesh
Cabinet	Heavy-gauge Steel Construction
Power Supply	Solid-state Dual-voltage Design





Headquartered in Sanford, North Carolina

CREATING THE RIGHT CLIMATE FOR YOU TO DO BUSINESS

Trion products have provided solutions to indoor air quality problems for more than 50 years. Products marketed under the Trion brand are part of Fedders Indoor Air Quality division of Fedders Corporation (NYSE:FJC), a leading global manufacturer and marketer of air treatment products. Trion is a registered trademark of Trion, Inc.

Trion Inc.

101 McNeill Road
Sanford, NC 27330, USA
Phone: 800-884-0002
Fax: 800-458-2379
www.trioninc.com
email: sales@trioninc.com

Trion, Ltd.

The Cavendish Centre
Winnall Close
Winchester, Hampshire,
SO23 0LB, UK
Phone: +44 (0) 1962 840465
Fax: +44 (0) 1962 828619
www.trion.co.uk
email: info@trion.co.uk

Trion Deutschland GmbH

Boschstr. 60
D - 50171 Kerpen
Phone: +49 (0) 2237 922-103
Fax: +49 (0) 2237 922-104
email: info@trion-deutschland.de

Fedders International Air Conditioning

A-30, Chintels House,
Kailash Colony
New Delhi
India 110048
Phone: 91 11 5173 0730
Fax: 91 11 5173 0743

Fedders International, Inc.

128 Joo Seng Road
#05-01
DP Computers Building
Singapore 368 356
Phone: (65) 6286 0995
Fax: (65) 6286 0859

Fedders International

No. 728 Fuzhou Road
Rm. 3002-3005
Raffles City Office Tower
Shanghai, P.R. China 200001
Phone: (86-21) 6340 3232
Fax: (86-21) 6340 3867/6340 3868